



# Pico-EZmate 1.2

## WIRE TO BOARD CONNECTOR SYSTEM

Receptacle Terminal	Receptacle Housing
	
Series: <a href="#">78172</a>	Series: <a href="#">78172</a>

PCB Header

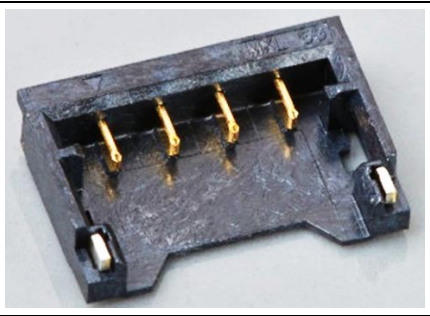
Series: <a href="#">78171</a>

[Pico-EZmate W-t-B Connectors Web Page](#)

[TABLE OF CONTENT](#)



THIS DOCUMENT CONTAINS INFORMATION THAT IS PROPRIETARY TO MOLEX ELECTRONIC TECHNOLOGIES, LLC AND SHOULD NOT BE USED WITHOUT WRITTEN PERMISSION

REVISION DESCRIPTION	PICO-EZMATE 1.2 WIRE TO BOARD CONNECTORS SMART SPEC						
CHANGE NO.	707036						
REVISED BY	PRAMOD	DATE	2022/05/17	DOC TYPE	DOC TYPE DESCRIPTION	DOC PART	SERIES
REV APPR BY	MRAMAKRISHNA	DATE	2022/05/20	PS	PRODUCT SPECIFICATION WORD	000	78172
INITIAL RELEASE				CUSTOMER	DOCUMENT NUMBER	REVISION	SHEET
INITIAL DRWN	MIKEDA01	DATE	2020/06/25	GENERAL	<b>781721000-PS</b>	<b>B1</b>	1 OF 18
INITIAL APPR	AIDA	DATE	2020/07/31				

**Table of Contents**

<u>ITEMS</u>	<u>PAGE</u>
<b>1.0 SCOPE.....</b>	<b>3</b>
<b>2.0 PRODUCT DESCRIPTION.....</b>	<b>3</b>
2.1 DESCRIPTION, SERIES NUMBER, AND LINKS .....	3
2.2 DIMENSIONS, MATERIALS, PLATINGS .....	3
2.3 ENVIRONMENTAL CONFORMANCE .....	3
2.4 SAFETY AGENCY LISTINGS.....	3
<b>3.0 APPLICABLE DOCUMENTS AND SPECIFICATION.....</b>	<b>4</b>
3.1 MOLEX DOCUMENTS .....	4
<b>4.0 ELECTRICAL PERFORMANCE RATINGS.....</b>	<b>4</b>
4.1 VOLTAGE .....	4
4.2 RATED CURRENT .....	4
4.3 CURRENT DERATING .....	4
4.4 TEMPERATURE.....	5
4.5 DURABILITY .....	5
<b>5.0 QUALIFICATION.....</b>	<b>5</b>
<b>6.0 PERFORMANCE.....</b>	<b>6</b>
6.1 ELECTRICAL PERFORMANCE .....	6
6.2 MECHANICAL PERFORMANCE .....	7
6.3 ENVIRONMENTAL PERFORMANCE .....	9
<b>7.0 INSERTION / WITHDRAWAL FORCE .....</b>	<b>11</b>
<b>8.0 CONTACT RESISTANCE MEASURING POINT.....</b>	<b>12</b>
<b>9.0 SOLDER INFORMATION.....</b>	<b>13</b>
9.1 SOLDER PROCESS TEMPERATURES .....	13
9.2 SOLDERING PROFILE FOR ALL CIRCUITS PRODUCTS.....	13
9.3 SOLDERING PROFILE FOR 2-5 CIRCUITS PRODUCTS.....	14
<b>10.0 PACKAGING .....</b>	<b>14</b>
<b>11.0 CABLE TIE AND / OR TWIST TIE LOCATION.....</b>	<b>15</b>
<b>12.0 NOTE.....</b>	<b>16</b>

[Pico-EZmate W-t-B Connectors Web Page](#)

[TABLE OF CONTENT](#)



THIS DOCUMENT CONTAINS INFORMATION THAT IS PROPRIETARY TO MOLEX ELECTRONIC TECHNOLOGIES, LLC AND SHOULD NOT BE USED WITHOUT WRITTEN PERMISSION

REVISION DESCRIPTION		<b>PICO-EZMATE 1.2 WIRE TO BOARD CONNECTORS SMART SPEC</b>					
CHANGE NO.	707036						
REVISED BY	PRAMOD	DATE	2022/05/17	DOC TYPE	DOC TYPE DESCRIPTION	DOC PART	SERIES
REV APPR BY	MRAMAKRISHNA	DATE	2022/05/20	PS	PRODUCT SPECIFICATION WORD	000	78172
INITIAL RELEASE			CUSTOMER		DOCUMENT NUMBER	REVISION	SHEET
INITIAL DRWN	MIKEDA01	DATE	2020/06/25	GENERAL	<b>781721000-PS</b>	<b>B1</b>	2 OF 18
INITIAL APPR	AIDA	DATE	2020/07/31				

## 1.0 SCOPE

This specification covers the performance requirements for Pico-EZmate 1.2 WIRE TO BOARD CONNECTOR series.

## 2.0 PRODUCT DESCRIPTION

### 2.1 DESCRIPTION, SERIES NUMBER, AND LINKS

DESCRIPTION	SERIES NUMBER	
Receptacle Terminal	Material: Phosphor bronze	<a href="#">781720410</a>
	Material: Copper alloy	<a href="#">781720411</a>
Receptacle Housing	2 to 5 circuits	<a href="#">78172000*</a>
	6, 7 circuits	<a href="#">78172500*</a>
Embossed Tape Packaging of Plug Assembly	2 to 5 circuits	<a href="#">7817100*</a>
	6, 7 circuits	<a href="#">78171500*</a>

### 2.2 DIMENSIONS, MATERIALS, PLATINGS

See the appropriate sales drawings for the information on dimensions, materials, platings and markings.

### 2.3 ENVIRONMENTAL CONFORMANCE

To find product compliance information:

- a. [Go to molex.com](http://molex.com)
- b. Enter the part number in the search field.
- c. At the bottom of the page go to "Environmental" to see compliance status.

### 2.4 SAFETY AGENCY LISTINGS

UL File Number: E29179  
 CSA File Number: LR19980

[Pico-EZmate W-t-B Connectors Web Page](#)

[TABLE OF CONTENT](#)



THIS DOCUMENT CONTAINS INFORMATION THAT IS PROPRIETARY TO MOLEX ELECTRONIC TECHNOLOGIES, LLC AND SHOULD NOT BE USED WITHOUT WRITTEN PERMISSION

REVISION DESCRIPTION	<b>PICO-EZMATE 1.2 WIRE TO BOARD CONNECTORS SMART SPEC</b>						
CHANGE NO.	707036						
REVISED BY	PRAMOD	DATE	2022/05/17	DOC TYPE	DOC TYPE DESCRIPTION	DOC PART	SERIES
REV APPR BY	MRAMAKRISHNA	DATE	2022/05/20	PS	PRODUCT SPECIFICATION WORD	000	78172
INITIAL RELEASE				CUSTOMER	DOCUMENT NUMBER	REVISION	SHEET
INITIAL DRWN	MIKEDA01	DATE	2020/06/25	GENERAL	<b>781721000-PS</b>	<b>B1</b>	3 OF 18
INITIAL APPR	AIDA	DATE	2020/07/31				

**3.0 APPLICABLE DOCUMENTS AND SPECIFICATION**

**3.1 MOLEX DOCUMENTS**

[Pico-Ezmate 1.2 w-t-b Connector System Application summary AS-78172-001](#)  
 ATS – Application Tooling Specification\*

\*Application Tooling Specification for terminals is not provided in this document. ATS for terminals can be available from respective terminal part number page in Molex.com

**4.0 ELECTRICAL PERFORMANCE RATINGS**

**4.1 VOLTAGE**

50 V AC (rms) / DC

**4.2 RATED CURRENT**

Wire Size	Rated Current (MAX.)	Insulation O.D.
AWG#28	1.5 A	φ0.6 mm - φ0.7 mm Insulation O.D. (UL3302)
AWG#30	1.0 A	

**4.3 CURRENT DERATING**

AWG	Amps[A]		
	2-circuit	3-circuit	4 to 7-circuit
Crimp Terminal: 781720410			
28	2.0	1.5	1.5
30	1.5	1.0	1.0
Crimp Terminal: 781720411			
28	2.5	2.0	1.5
30	2.0	1.0	1.0

1. Values are for REFERENCE ONLY.
2. Current deratings are based on not exceeding 30° C Temperature Rise
3. Temperature Rise is measured in Solder Tail of crimp terminal.
4. PCB trace design can greatly affect temperature rise results.
5. Data is for all circuits powered.

[Pico-EZmate W-t-B Connectors Web Page](#)

[TABLE OF CONTENT](#)



THIS DOCUMENT CONTAINS INFORMATION THAT IS PROPRIETARY TO MOLEX ELECTRONIC TECHNOLOGIES, LLC AND SHOULD NOT BE USED WITHOUT WRITTEN PERMISSION

REVISION DESCRIPTION	<b>PICO-EZMATE 1.2 WIRE TO BOARD CONNECTORS SMART SPEC</b>								
CHANGE NO.	707036								
REVISED BY	PRAMOD	DATE	2022/05/17	DOC TYPE	DOC TYPE DESCRIPTION		DOC PART	SERIES	
REV APPR BY	MRAMAKRISHNA	DATE	2022/05/20	PS	PRODUCT SPECIFICATION WORD		000	78172	
INITIAL RELEASE				CUSTOMER		DOCUMENT NUMBER		REVISION	SHEET
INITIAL DRWN	MIKEDA01	DATE	2020/06/25	GENERAL		<b>781721000-PS</b>		<b>B1</b>	4 OF 18
INITIAL APPR	AIDA	DATE	2020/07/31						

**4.4 TEMPERATURE**

Ambient Temperature Range\* : - 40 °C ~ + 105 °C  
(Not freeze in low temperature)

NOTE:

- \*1. Non-operating connectors after reflow must follow the operating temperature range condition.
- \*2. This includes the terminal temperature rise generated by conducting electricity.
- \*3. Applicable wires must also meet the specified temperature range.

**4.5 DURABILITY**

Plating Type	Number of Cycles
Gold Plated	10 cycles

**5.0 QUALIFICATION**

Sample selection is in accordance with EIA-364-1000.

[Pico-EZmate W-t-B Connectors Web Page](#)

[TABLE OF CONTENT](#)



THIS DOCUMENT CONTAINS INFORMATION THAT IS PROPRIETARY TO MOLEX ELECTRONIC TECHNOLOGIES, LLC AND SHOULD NOT BE USED WITHOUT WRITTEN PERMISSION

REVISION DESCRIPTION	<b>PICO-EZMATE 1.2 WIRE TO BOARD CONNECTORS SMART SPEC</b>						
CHANGE NO.	707036						
REVISED BY	PRAMOD	DATE	2022/05/17	DOC TYPE	DOC TYPE DESCRIPTION	DOC PART	SERIES
REV APPR BY	MRAMAKRISHNA	DATE	2022/05/20	PS	PRODUCT SPECIFICATION WORD	000	78172
INITIAL RELEASE				CUSTOMER	DOCUMENT NUMBER	REVISION	SHEET
INITIAL DRWN	MIKEDA01	DATE	2020/06/25	GENERAL	<b>781721000-PS</b>	<b>B1</b>	5 OF 18
INITIAL APPR	AIDA	DATE	2020/07/31				

**6.0 PERFORMANCE**

**6.1 ELECTRICAL PERFORMANCE**

ITEM	DESCRIPTION	TEST CONDITION	REQUIREMENT	
6.1.1	Contact Resistance	Mate connectors and measured by dry circuit, 20 mV MAX., 10 mA. MAX. (JIS C5402-2-1)	20 milliohms MAX.	
6.1.2	Insulation Resistance	Mate connectors and apply 500 V DC between adjacent terminal or ground. (JIS C5402-3-1 / MIL-STD-202 Method 302)	100 Megohms MIN.	
6.1.3	Dielectric Strength	Mate connectors and apply 500 V AC(rms) for 1 minute between adjacent terminal or ground. (JIS C5402-4-1 / MIL-STD-202 Method 301)	No Damage on function	
6.1.4	Contact Resistance on crimped portion	Crimp the applicable wire to the terminal, measured by dry circuit, 20 mV MAX., 10 mA. MAX.	5.0 milliohms MAX.	
6.1.5	Temperature Rise	Mate connectors and all crimp terminals shall be connected in a direct series. The temperature rise shall be measured when the terminal reaches thermal equilibrium allowable current. (UL498)	Temperature Rise	30 °C MAX.

[Pico-EZmate W-t-B Connectors Web Page](#)

[TABLE OF CONTENT](#)



THIS DOCUMENT CONTAINS INFORMATION THAT IS PROPRIETARY TO MOLEX ELECTRONIC TECHNOLOGIES, LLC AND SHOULD NOT BE USED WITHOUT WRITTEN PERMISSION

REVISION DESCRIPTION	<b>PICO-EZMATE 1.2 WIRE TO BOARD CONNECTORS SMART SPEC</b>						
CHANGE NO.	707036						
REVISED BY	PRAMOD	DATE	2022/05/17	DOC TYPE	DOC TYPE DESCRIPTION	DOC PART	SERIES
REV APPR BY	MRAMAKRISHNA	DATE	2022/05/20	PS	PRODUCT SPECIFICATION WORD	000	78172
INITIAL RELEASE				CUSTOMER	DOCUMENT NUMBER	REVISION	SHEET
INITIAL DRWN	MIKEDA01	DATE	2020/06/25	GENERAL	<b>781721000-PS</b>	<b>B1</b>	6 OF 18
INITIAL APPR	AIDA	DATE	2020/07/31				

**6.2 MECHANICAL PERFORMANCE**

ITEM	DESCRIPTION	TEST CONDITION		REQUIREMENT
6.2.1	Insertion and Withdrawal Force	Insert and withdraw connectors at the speed rate of 25 ± 3 mm/minute. Withdrawal Method: Refer section 7 for image. Pull up the cable vertically and apply same tension to header assembly		Refer to section 7
6.2.2	Crimping Pull out Force	Fix the crimped terminal to the jig, apply axial pull out force on the wire at the speed rate of 25 ± 3 mm/minute. (JIS C5402-16-4)	AWG#28	10 N {1.0 kgf} MIN.
			AWG#30	5 N {0.5 kgf} MIN.
6.2.3	Crimp Terminal Insertion Force	Insert the crimped terminal at the speed rate of 25 ± 3 mm/minute into the housing.		14.7 N {1.5 kgf} MAX.
6.2.4	Crimp Terminal Retention Force	Apply axial pull out force at the speed rate of 25 ± 3 mm/minute on the crimped terminal assembled in the housing.		4 N {0.4 kgf} MIN.
6.2.5	Header Terminal Retention Force	Apply axial pull out force at the speed rate of 25 ± 3 mm/minute on the terminal assembled in the housing.		0.5 N {0.05 kgf} MIN.
6.2.6	Repeated Insertion / Withdrawal	Insert and withdraw connectors 10 cycles repeatedly by rate of less than 10 cycles per minute.	Contact Resistance	20 milliohms MAX.
			Insertion Force	Must meet section 7
			Withdrawal Force	Must meet section 7
6.2.7	Vibration	Mate connectors and subject to the following vibration conditions, for a period of 2 hours in each of 3 mutually perpendicular axes, passing DC 1mA during the test. (Fix the cable at test.) Amplitude : 1.5 mm P-P Frequency : 10~55~10 Hz in 1 minute. Duration : 2 hours in each X.Y.Z. axes. (JIS C 60068-2-6 / MIL-STD-202 Method 201)	Appearance	No Damage on function
			Contact Resistance	20 milliohms MAX.
			Discontinuity	1 microsecond MAX.

[Pico-EZmate W-t-B Connectors Web Page](#)

[TABLE OF CONTENT](#)



THIS DOCUMENT CONTAINS INFORMATION THAT IS PROPRIETARY TO MOLEX ELECTRONIC TECHNOLOGIES, LLC AND SHOULD NOT BE USED WITHOUT WRITTEN PERMISSION

REVISION DESCRIPTION	<b>PICO-EZMATE 1.2 WIRE TO BOARD CONNECTORS SMART SPEC</b>						
CHANGE NO.	707036						
REVISED BY	PRAMOD	DATE	2022/05/17	DOC TYPE	DOC TYPE DESCRIPTION	DOC PART	SERIES
REV APPR BY	MRAMAKRISHNA	DATE	2022/05/20	PS	PRODUCT SPECIFICATION WORD	000	78172
INITIAL RELEASE				CUSTOMER	DOCUMENT NUMBER	REVISION	SHEET
INITIAL DRWN	MIKEDA01	DATE	2020/06/25	GENERAL	<b>781721000-PS</b>	<b>B1</b>	7 OF 18
INITIAL APPR	AIDA	DATE	2020/07/31				

**6.2 MECHANICAL PERFORMANCE CONTINUED**

ITEM	DESCRIPTION	TEST CONDITION	REQUIREMENT	
6.2.8	Mechanical Shock	Mate connectors and subject to the following shock conditions. 3 shocks shall be applied 6 directions along 3 mutually perpendicular axes ( $\pm x, \pm y, \pm z$ , each), passing DC 1 mA current during the test. (Total of 18 shocks) Test pulse : Half Sine Peak value : 490 m/s <sup>2</sup> {50 G} Duration : 11 ms (JIS C60068-2-27 / MIL-STD-202 Method 213)	Appearance	No Damage on function
			Contact Resistance	40 milliohms MAX.
			Discontinuity	1 microsecond MAX.

[Pico-EZmate W-t-B Connectors Web Page](#)

[TABLE OF CONTENT](#)



THIS DOCUMENT CONTAINS INFORMATION THAT IS PROPRIETARY TO MOLEX ELECTRONIC TECHNOLOGIES, LLC AND SHOULD NOT BE USED WITHOUT WRITTEN PERMISSION

REVISION DESCRIPTION	<b>PICO-EZMATE 1.2 WIRE TO BOARD CONNECTORS SMART SPEC</b>							
CHANGE NO.	707036							
REVISED BY	PRAMOD	DATE	2022/05/17	DOC TYPE	DOC TYPE DESCRIPTION		DOC PART	SERIES
REV APPR BY	MRAMAKRISHNA	DATE	2022/05/20	PS	PRODUCT SPECIFICATION WORD		000	78172
INITIAL RELEASE				CUSTOMER	DOCUMENT NUMBER		REVISION	SHEET
INITIAL DRWN	MIKEDA01	DATE	2020/06/25	GENERAL	<b>781721000-PS</b>		<b>B1</b>	8 OF 18
INITIAL APPR	AIDA	DATE	2020/07/31					

**6.3 ENVIRONMENTAL PERFORMANCE**

ITEM	DESCRIPTION	TEST CONDITION	REQUIREMENT	
6.3.1	Temperature Cycling	Mate connectors and subject to the following conditions for 5 cycles. Upon completion of the exposure period, the test specimens shall be conditioned at ambient room conditions for 1 to 2 hours, after which the specified measurements shall be performed. 5 cycles of : a) - 40 ± 3 °C 30 minutes b) + 105 ± 2 °C 30 minutes Shift time : Within 5 minutes (JIS C60068-2-14)	Appearance	No Damage on function
			Contact Resistance	20 milliohms MAX. (Change from initial)
6.3.2	Heat Resistance	Mate connectors and expose to 105 ± 2 °C for 96 hours. Upon completion of the exposure period, the test specimens shall be conditioned at ambient room conditions for 1 to 2 hours, after which the specified measurements shall be performed. (JIS C60068-2-2 / MIL-STD-202 Method 108)	Appearance	No Damage on function
			Contact Resistance	20 milliohms MAX.
6.3.3	Cold Resistance	Mate connectors and expose to -40 ± 3 °C for 96 hours. Upon completion of the exposure period, the test specimens shall be conditioned at ambient room conditions for 1 to 2 hours, after which the specified measurements shall be performed. (JIS C60068-2-1)	Appearance	No Damage on function
			Contact Resistance	40 milliohms MAX.
6.3.4	Humidity	Mate connectors and expose to 60 ± 2 °C, relative humidity 90 to 95% for 96 hours. Upon completion of the exposure period, the test specimens shall be conditioned at ambient room conditions for 1 to 2 hours, after which the specified measurements shall be performed. (JIS C60068-2-78 / MIL-STD-202 Method 103)	Appearance	No Damage on function
			Contact Resistance	40 milliohms MAX.
			Dielectric Strength	Must meet 6.1.3
			Insulation Resistance	Must meet 6.1.2

[Pico-EZmate W-t-B Connectors Web Page](#)

[TABLE OF CONTENT](#)



THIS DOCUMENT CONTAINS INFORMATION THAT IS PROPRIETARY TO MOLEX ELECTRONIC TECHNOLOGIES, LLC AND SHOULD NOT BE USED WITHOUT WRITTEN PERMISSION

REVISION DESCRIPTION	<b>PICO-EZMATE 1.2 WIRE TO BOARD CONNECTORS SMART SPEC</b>						
CHANGE NO.	707036						
REVISED BY	PRAMOD	DATE	2022/05/17	DOC TYPE	DOC TYPE DESCRIPTION	DOC PART	SERIES
REV APPR BY	MRAMAKRISHNA	DATE	2022/05/20	PS	PRODUCT SPECIFICATION WORD	000	78172
INITIAL RELEASE				CUSTOMER	DOCUMENT NUMBER	REVISION	SHEET
INITIAL DRWN	MIKEDA01	DATE	2020/06/25	GENERAL	<b>781721000-PS</b>	<b>B1</b>	9 OF 18
INITIAL APPR	AIDA	DATE	2020/07/31				

**6.3 ENVIRONMENTAL PERFORMANCE CONTINUED**

ITEM	DESCRIPTION	TEST CONDITION	REQUIREMENT	
6.3.5	Salt Spray	Mate connectors and expose to the following salt mist conditions. Upon completion of the exposure period, salt deposits shall be removed by a gentle wash or dip in running water, after which the specified measurements shall be performed. NaCl solution Concentration : 5 ± 1% Spray time : 48 ± 4 hours Ambient temperature : 35 ± 2 °C (JIS 60068-2-11 / MIL-STD-202 Method 101)	Appearance	No Damage on function
			Contact Resistance	40 milliohms MAX.
6.3.6	SO <sub>2</sub> Gas	Mated connectors and expose to the conditions of 50 ± 5 ppm SO <sub>2</sub> gas ambient temperature 40 ± 2 °C for 24 hours.	Appearance	No Damage on function
			Contact Resistance	40 milliohms MAX.
6.3.7	NH <sub>3</sub> Gas	Mated connectors and expose to the conditions of NH <sub>3</sub> gas evaporating from 28% NH <sub>3</sub> solution for 40 minutes. (Rate is 25 ml per 1L)	Appearance	No Damage on function
			Contact Resistance	40 milliohms MAX.
6.3.8	Solderability	Dip terminal or pin into flux, and immerse the area up to 0.2 mm from the bottom of the housing into solder molten at 245 ± 3 °C for 3 ± 0.5 sec.	Solder Wetting	95% of immersed area must show no voids, pin holes
6.3.9	Resistance to Soldering Heat	<u>(Reflow by IR Reflow Machine)</u> Using the reflow profile condition below section 10, the product was reflowed.	Appearance	No Damage
		<u>(Reflow by Manual Soldering iron)</u> Using a soldering iron (350 ± 5°C for 5 seconds MAX) heat. However, do not apply excessive pressure to either the terminals or fitting nails.		

( ) : Reference Standard  
 { } : Reference Unit

[Pico-EZmate W-t-B Connectors Web Page](#)

[TABLE OF CONTENT](#)



THIS DOCUMENT CONTAINS INFORMATION THAT IS PROPRIETARY TO MOLEX ELECTRONIC TECHNOLOGIES, LLC AND SHOULD NOT BE USED WITHOUT WRITTEN PERMISSION

REVISION DESCRIPTION	<b>PICO-EZMATE 1.2 WIRE TO BOARD CONNECTORS SMART SPEC</b>						
CHANGE NO.	707036						
REVISED BY	PRAMOD	DATE	2022/05/17	DOC TYPE	DOC TYPE DESCRIPTION	DOC PART	SERIES
REV APPR BY	MRAMAKRISHNA	DATE	2022/05/20	PS	PRODUCT SPECIFICATION WORD	000	78172
INITIAL RELEASE				CUSTOMER	DOCUMENT NUMBER	REVISION	SHEET
INITIAL DRWN	MIKEDA01	DATE	2020/06/25	GENERAL	<b>781721000-PS</b>	<b>B1</b>	10 OF 18
INITIAL APPR	AIDA	DATE	2020/07/31				

**7.0 INSERTION / WITHDRAWAL FORCE**

No. of CKT	UNIT	Insertion (MAX.)			Withdrawal (MIN.)		
		1st	3rd	10th	1st	3rd	10th
2	N {kgf}	18 {1.8}	18 {1.8}	18 {1.8}	4.0 {0.41}	1.8 {0.18}	1.2 {0.12}
3	N {kgf}	21 {2.1}	21 {2.1}	21 {2.1}	4.0 {0.41}	1.8 {0.18}	1.2 {0.12}
4	N {kgf}	24 {2.4}	24 {2.4}	24 {2.4}	4.0 {0.41}	1.8 {0.18}	1.2 {0.12}
5	N {kgf}	27 {2.8}	27 {2.8}	27 {2.8}	4.0 {0.41}	1.8 {0.18}	1.2 {0.12}
6	N {kgf}	30 {3.1}	30 {3.1}	30 {3.1}	2.5 {0.26}	1.8 {0.18}	1.2 {0.12}
7	N {kgf}	30 {3.1}	30 {3.1}	30 {3.1}	2.5 {0.26}	1.8 {0.18}	1.2 {0.12}

{ } : Reference Unit

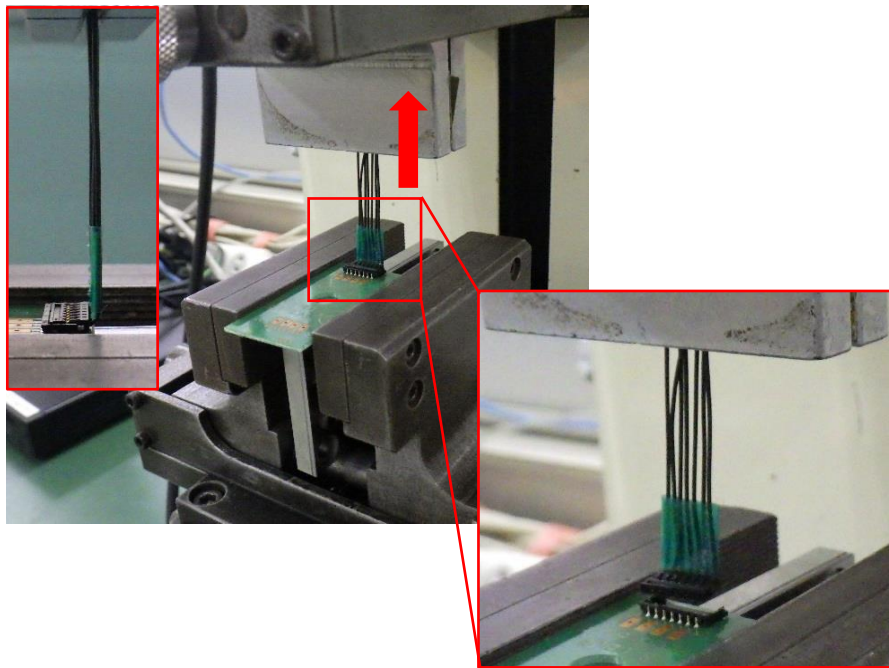

[Pico-EZmate W-t-B Connectors Web Page](#)

[TABLE OF CONTENT](#)



THIS DOCUMENT CONTAINS INFORMATION THAT IS PROPRIETARY TO MOLEX ELECTRONIC TECHNOLOGIES, LLC AND SHOULD NOT BE USED WITHOUT WRITTEN PERMISSION

REVISION DESCRIPTION	<b>PICO-EZMATE 1.2 WIRE TO BOARD CONNECTORS SMART SPEC</b>						
CHANGE NO.							
REVISED BY	PRAMOD	DATE	2022/05/17	DOC TYPE	DOC TYPE DESCRIPTION	DOC PART	SERIES
REV APPR BY	MRAMAKRISHNA	DATE	2022/05/20	PS	PRODUCT SPECIFICATION WORD	000	78172
INITIAL RELEASE				CUSTOMER	DOCUMENT NUMBER	REVISION	SHEET
INITIAL DRWN	MIKEDA01	DATE	2020/06/25	GENERAL	<b>781721000-PS</b>	<b>B1</b>	11 OF 18
INITIAL APPR	AIDA	DATE	2020/07/31				

**8.0**

**CONTACT RESISTANCE MEASURING POINT**

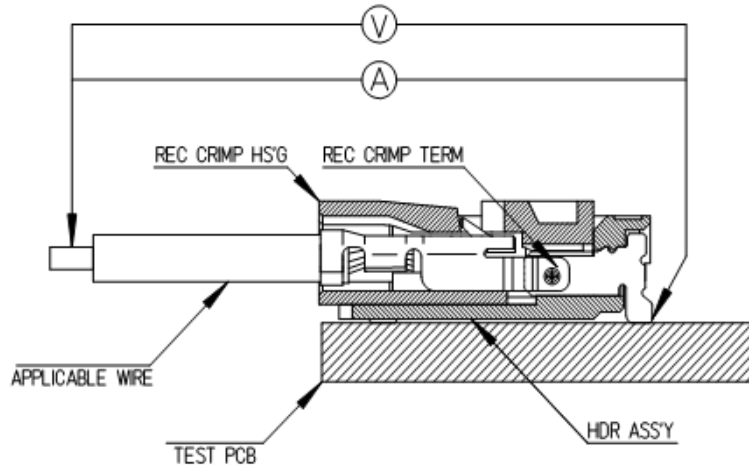

Contact Resistance  $m\Omega = V/A$

[Pico-EZmate W-t-B Connectors Web Page](#)

[TABLE OF CONTENT](#)



THIS DOCUMENT CONTAINS INFORMATION THAT IS PROPRIETARY TO MOLEX ELECTRONIC TECHNOLOGIES, LLC AND SHOULD NOT BE USED WITHOUT WRITTEN PERMISSION

REVISION DESCRIPTION	<b>PICO-EZMATE 1.2 WIRE TO BOARD CONNECTORS SMART SPEC</b>						
CHANGE NO.	707036						
REVISED BY	PRAMOD	DATE	2022/05/17	DOC TYPE	DOC TYPE DESCRIPTION	DOC PART	SERIES
REV APPR BY	MRAMAKRISHNA	DATE	2022/05/20	PS	PRODUCT SPECIFICATION WORD	000	78172
INITIAL RELEASE				CUSTOMER	DOCUMENT NUMBER	REVISION	SHEET
INITIAL DRWN	MIKEDA01	DATE	2020/06/25	GENERAL	<b>781721000-PS</b>	<b>B1</b>	12 OF 18
INITIAL APPR	AIDA	DATE	2020/07/31				

**9.0 SOLDER INFORMATION**

These specifications establish standard solderability test methods used to evaluate a products ability to accept molten solder. Solder Process Temperatures and Reflow Solder Profiles will vary based on application, equipment, solder paste, PCB thickness, etc.

**9.1 SOLDER PROCESS TEMPERATURES**

Reflow Solder Temperature: 250 °C Maximum

**9.2 SOLDERING PROFILE FOR ALL CIRCUITS PRODUCTS**

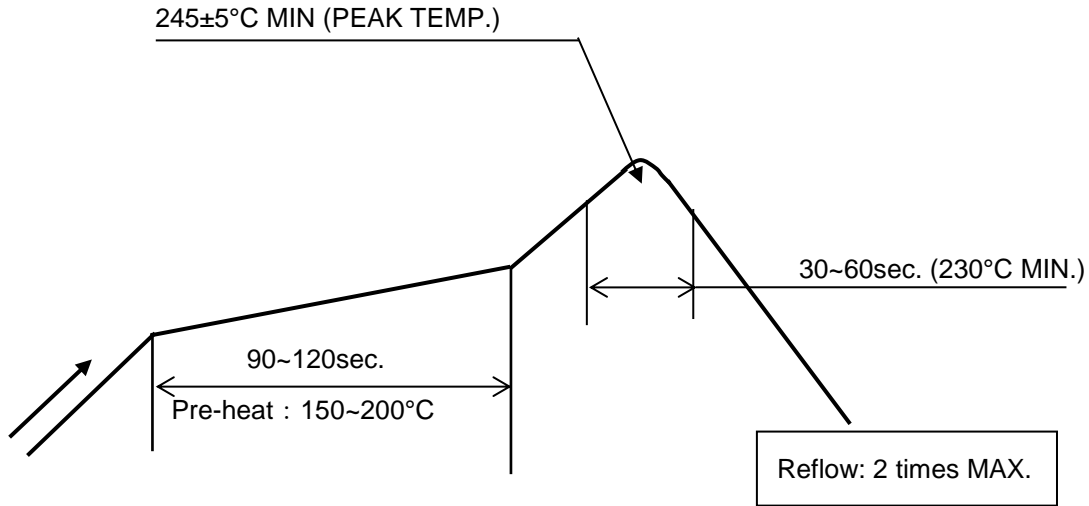

TEMPERATURE CONDITION GRAPH

(Temperature is measured at the soldering area on the surface of PCB)

NOTE: Please check the mount condition (reflow soldering condition) by your own devices beforehand, because the condition changes by the soldering devices, printed circuit boards (PCB), and so on. Although tail of terminal and nail may discolor, a solderability does not have a problem.

[Pico-EZmate W-t-B Connectors Web Page](#)

[TABLE OF CONTENT](#)



THIS DOCUMENT CONTAINS INFORMATION THAT IS PROPRIETARY TO MOLEX ELECTRONIC TECHNOLOGIES, LLC AND SHOULD NOT BE USED WITHOUT WRITTEN PERMISSION

REVISION DESCRIPTION	<b>PICO-EZMATE 1.2 WIRE TO BOARD CONNECTORS SMART SPEC</b>						
CHANGE NO.							
REVISED BY	PRAMOD	DATE	2022/05/17	DOC TYPE	DOC TYPE DESCRIPTION	DOC PART	SERIES
REV APPR BY	MRAMAKRISHNA	DATE	2022/05/20	PS	PRODUCT SPECIFICATION WORD	000	78172
INITIAL RELEASE				CUSTOMER	DOCUMENT NUMBER	REVISION	SHEET
INITIAL DRWN	MIKEDA01	DATE	2020/06/25	GENERAL	<b>781721000-PS</b>	<b>B1</b>	13 OF 18
INITIAL APPR	AIDA	DATE	2020/07/31				

**9.3 SOLDERING PROFILE FOR 2-5 CIRCUITS PRODUCTS**

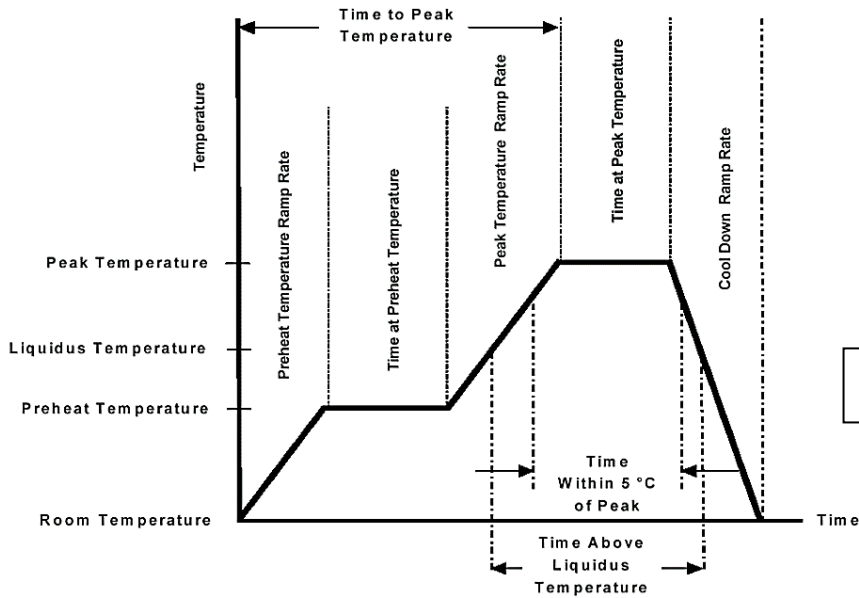

Reflow: 1 times MAX.

Description	Requirement
Average Ramp Rate	3°C/sec Max
Preheat Temperature	150°C Min to 200°C Max
Preheat Time	60 to 180 sec
Ramp to Peak	3°C/sec Max
Time over Liquids (217°C)	60 to 150 sec
Peak Temperature	260 +0/-5°C
Time within 5°C of Peak	10 to 15 sec
Ramp - Cool Down	6°C/sec Max
Time 25°C to Peak	8 min Max

**NOTE:**

1. The reflow conditions are the same as the conditions described in previous PS-78172-010.
2. Please check the mount condition (reflow soldering condition) by your own devices beforehand, because the condition changes by the soldering devices, printed circuit boards (PCB), and so on. Although tail of terminal and nail may discolor, a solderability does not have a problem.

**10.0 PACKAGING**

Parts shall be packaging to protect the parts from damage during standard shipping, storage, and handling. Refer Molex.com specific part number webpage to get the exact packaging document for that item.

[Pico-EZmate W-t-B Connectors Web Page](#)

[TABLE OF CONTENT](#)



THIS DOCUMENT CONTAINS INFORMATION THAT IS PROPRIETARY TO MOLEX ELECTRONIC TECHNOLOGIES, LLC AND SHOULD NOT BE USED WITHOUT WRITTEN PERMISSION

REVISION DESCRIPTION		<b>PICO-EZMATE 1.2 WIRE TO BOARD CONNECTORS SMART SPEC</b>					
CHANGE NO.	707036						
REVISED BY	PRAMOD	DATE	2022/05/17	DOC TYPE	DOC TYPE DESCRIPTION	DOC PART	SERIES
REV APPR BY	MRAMAKRISHNA	DATE	2022/05/20	PS	PRODUCT SPECIFICATION WORD	000	78172
INITIAL RELEASE				CUSTOMER	DOCUMENT NUMBER	REVISION	SHEET
INITIAL DRWN	MIKEDA01	DATE	2020/06/25	GENERAL	<b>781721000-PS</b>	<b>B1</b>	14 OF 18
INITIAL APPR	AIDA	DATE	2020/07/31				

**11.0 CABLE TIE AND / OR TWIST TIE LOCATION**

CKT Size	Dim T Min.
2-7 ckt	10 mm

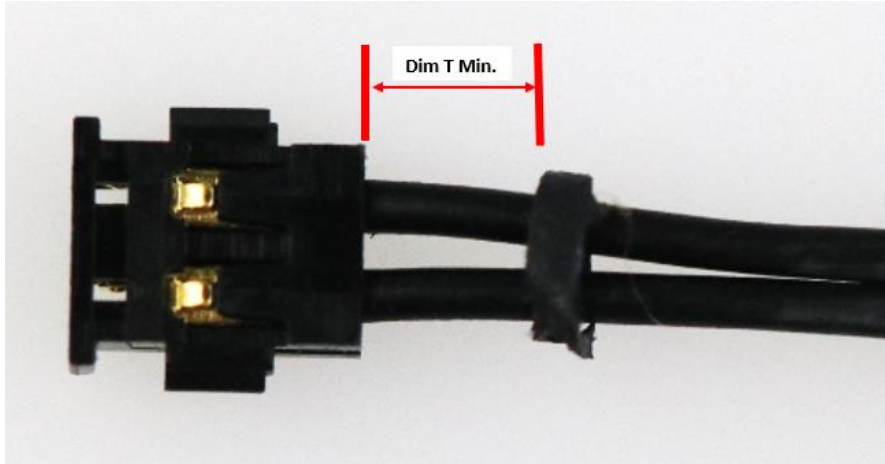

The “T” dimension defines a “free” length of wire, or a length of wire that is not subject to significant bias by external factors such as a wire tie, wire twisting, or other means of bending or deforming of the wires that repositions them from their natural relaxed state or location where they enter the housing. Wires are to be dressed in such a manner to allow the terminals to float freely in the pocket. This dimension is general recommendation and may need to be adjusted for different wire gauges and wire type and insulation thickness and insulation material.

[Pico-EZmate W-t-B Connectors Web Page](#)

[TABLE OF CONTENT](#)



THIS DOCUMENT CONTAINS INFORMATION THAT IS PROPRIETARY TO MOLEX ELECTRONIC TECHNOLOGIES, LLC AND SHOULD NOT BE USED WITHOUT WRITTEN PERMISSION

REVISION DESCRIPTION	<b>PICO-EZMATE 1.2 WIRE TO BOARD CONNECTORS SMART SPEC</b>						
CHANGE NO.	707036						
REVISED BY	PRAMOD	DATE	2022/05/17	DOC TYPE	DOC TYPE DESCRIPTION	DOC PART	SERIES
REV APPR BY	MRAMAKRISHNA	DATE	2022/05/20	PS	PRODUCT SPECIFICATION WORD	000	78172
INITIAL RELEASE				CUSTOMER	DOCUMENT NUMBER	REVISION	SHEET
INITIAL DRWN	MIKEDA01	DATE	2020/06/25	GENERAL	<b>781721000-PS</b>	<b>B1</b>	15 OF 18
INITIAL APPR	AIDA	DATE	2020/07/31				

**12.0 NOTE**

1. There is no influence in the product performance though the black spot or bubble etc. might be confirmed to the plastic part of this product and the shade might be different (discoloration by secular distortion etc.).
2. A few scratches may be confirmed to the surface of the housing and the plating of this product. However, There is no problem in the product performance.
3. The wound of friction might adhere to externals because the tin plating is used for nail. But there is no influence in the product performance.
4. Discoloration of the plastic part of this product can result from exposure to ultraviolet light. There is no problem in the product performance.
5. When this product is used at a place where exposure to water could be expected, please handle with appropriate care to avoid damage from water. There is a possibility of causing insulated malfunction between the circuits.
6. Please do not conduct any washing process on the connectors because it may damage the product's function.
7. Please do not use the connectors in a condition where the wire, PCB, or the contact area is experiencing a sympathetic vibration of wires and PCB, and constant movement of devices. This may cause a defect in the contact due to the contact area being worn down. Therefore, please fix wires and PCB on the chassis, and reduces sympathetic vibration.
8. Please do not do work that the load hangs in the connectors like the carrying of the substrate etc. with the connectors engage. There is a case where it causes the connectors damage etc.
9. After mated the connectors, please do not allow the PCBs to apply pressure on the connectors in either the pitch direction, the span direction or rotational direction. It may cause damage to the connectors and may crack the soldering.
10. Please try to prevent any external forces or shock from being applied to the connectors while the cable assembly is in process, when it is being packaged, or while it is in transportation. This may cause deformation and damage to the connectors and cause a defect in the product's performance.
11. When using this product, please ensure that the specification for rated current per circuit is followed. Do not allow the sum of the current used on several circuits to exceed the maximum allowable current.
12. This product is not designed for the mating and unmating of the connectors to be performed under the condition of an active electrical circuit. It may cause a spark and product defect if the connectors are mated and unmated in this way.
13. The applicable wire for this connector, in principle, is tin-plated copper stranded wire. Please consult us and evaluate it in advance when using other wires.
14. Please keep enough clearance between connectors and chassis of your application in order not to apply pressure on the connectors.
15. Please tie the cable at least 10 mm away from the edge of the connectors and try to ensure that the force is applied evenly on all of the wires.

[Pico-EZmate W-t-B Connectors Web Page](#)

[TABLE OF CONTENT](#)



THIS DOCUMENT CONTAINS INFORMATION THAT IS PROPRIETARY TO MOLEX ELECTRONIC TECHNOLOGIES, LLC AND SHOULD NOT BE USED WITHOUT WRITTEN PERMISSION

REVISION DESCRIPTION	<b>PICO-EZMATE 1.2 WIRE TO BOARD CONNECTORS SMART SPEC</b>						
CHANGE NO.	707036						
REVISED BY	PRAMOD	DATE	2022/05/17	DOC TYPE	DOC TYPE DESCRIPTION	DOC PART	SERIES
REV APPR BY	MRAMAKRISHNA	DATE	2022/05/20	PS	PRODUCT SPECIFICATION WORD	000	78172
INITIAL RELEASE				CUSTOMER	DOCUMENT NUMBER	REVISION	SHEET
INITIAL DRWN	MIKEDA01	DATE	2020/06/25	GENERAL	<b>781721000-PS</b>	<b>B1</b>	16 OF 18
INITIAL APPR	AIDA	DATE	2020/07/31				

16. When extracting a crimp terminal from the housing using a jig, it may deform the housing lance and therefore reduce the terminal retention force enormously after re-inserting of the terminal. Therefore, please ensure to use a new housing after repairing the crimp terminals.
17. The cable assembly should not have a constant stress or pulling force applied on it when it is in the mated condition. This phenomenon may damage the contact area or wiring area (crimping). Therefore, when designing the wire positioning, please ensure that there is enough length of wire to avoid stress on the connectors.
18. Please hold wires all together lightly and please withdraw receptacle housing slowly, axially and straightly. Please avoid withdrawing them with an angle and roughly. That might cause damage to connector.
19. Do not deform the movable part as lock part and lance part of Plug. HS'G and terminals on purpose. It would lead to product failure.
20. If you leave any soldering area on this product open, there may be the possibility of a missing terminal short circuiting between pins, terminal buckling or the potential for the connectors to come off of the PCB. Therefore, please solder all of the terminals and fitting nails on the PCB.
21. If there is accidental contact with the connectors while it is going through the reflow machine, there may be deformation or damage caused to the connectors. Please check to prevent this.
22. Please do not touch the terminals and fitting nails before or after mounted the connectors onto the PCB.
23. Please do not stack the PCB directly after mounted the connectors on it.
24. Please conduct it under the condition of the specifications when repairing by hand soldering iron after mounting. In the case of practicing beyond the condition, the backlash, the change in the contact gap, the deformation of the mold and the melting, etc. may cause damage.
25. When conducting manual repairs using a soldering iron, please do not use more solder and flux than needed. This may cause solder wicking and flux wicking issues, and it will eventually cause a contact defect and functional issues.
26. Please do not use the connectors alone to provide mechanical support for the PCB. Please ensure that there is a fixed structure on the phone chassis or other component support for the PCB.
27. In the case of changing our recommended board pattern size and designing, please consult in advance because it may cause a fatal defect.
28. It is necessary to consult separately when mount product on a special PCB or FPC.
29. Please do the mating as much as possible to along to mating axis. At this time, positioning each side of external faces of receptacle housing and plug and push to mating until both connectors strikes each other (complete mating position). In the case of diagonal mating, touch with external faces with receptacle housing and plug under the angle of 10°lightly and push to mating in order to avoid the connector break.
30. When withdrawing connectors oblique direction or when withdrawing with strong tension to specific cable, there is a possibility that it does not satisfy requirement of withdrawal force.
31. There is no influence in the product performance though the twist might be generated in the terminal plating part according to the reflow condition.

[Pico-EZmate W-t-B Connectors Web Page](#)

[TABLE OF CONTENT](#)



THIS DOCUMENT CONTAINS INFORMATION THAT IS PROPRIETARY TO MOLEX ELECTRONIC TECHNOLOGIES, LLC AND SHOULD NOT BE USED WITHOUT WRITTEN PERMISSION

REVISION DESCRIPTION	<b>PICO-EZMATE 1.2 WIRE TO BOARD CONNECTORS SMART SPEC</b>						
CHANGE NO.	707036						
REVISED BY	PRAMOD	DATE	2022/05/17	DOC TYPE	DOC TYPE DESCRIPTION	DOC PART	SERIES
REV APPR BY	MRAMAKRISHNA	DATE	2022/05/20	PS	PRODUCT SPECIFICATION WORD	000	78172
INITIAL RELEASE				CUSTOMER	DOCUMENT NUMBER	REVISION	SHEET
INITIAL DRWN	MIKEDA01	DATE	2020/06/25	GENERAL	<b>781721000-PS</b>	<b>B1</b>	17 OF 18
INITIAL APPR	AIDA	DATE	2020/07/31				

- 32. There is no influence in the product performance though discoloration might be generated in the resin according to the reflow condition.
- 33. Although there might be some discoloration seen on the soldering tail after reflow, this will not influence the product's performance.
- 34. Please investigate the mounting condition (reflow soldering condition) on your own devices beforehand. The mounting conditions may change due to the soldering temperature, soldering paste, IR reflow machine, Nitrogen reflow machine, and the type of PCB. The different mounting conditions may have an influence on the product's performance.
- 35. Thickness 0.1mm, aperture ratio 100% stencil is used in this specification.
- 36. The mounting specification for coplanarity does not include the influence of warpage of the PCB. The warpage of the PCB should be a maximum of 0.02 mm if measuring from one connector edge to the other.
- 37. Coplanarity is assured only before mounting. There is no guarantee of coplanarity after mounting and in the reflow.

No.38 to 40 apply only to the products using polyamide materials in the following chart.

Receptacle Housing	6,7circuit	78172500*
Embossed tape packaging of Plug Assembly	6,7circuit	78171500*

- 38. The housing material of this product is made from a high heat resistant polyamide. The soldering condition and the water absorption properties of the housing material may cause blistering on the housing surface. Because this blister is not caused by property change, it does not damage the product's features.
- 39. Because of property of housing resin, blister might be generated during reflow heating by hygroscopicity. When more than six months after unpacking the humidity prevention package of product, baking is recommended with below condition. Baking condition : put in 50 °C temperature chamber for 10 hours.
- 40. Because the receptacle housing material of this product is using polyamide, the water absorption status of the housing material might change insertion force, withdrawal force, or the feeling of insertion. Its excessive water absorption may cause to interfere with insertion a little bit or to weaken the click feeling of the lock when mating. However, it does not damage the product's features and functions.

[Pico-EZmate W-t-B Connectors Web Page](#)

[TABLE OF CONTENT](#)



THIS DOCUMENT CONTAINS INFORMATION THAT IS PROPRIETARY TO MOLEX ELECTRONIC TECHNOLOGIES, LLC AND SHOULD NOT BE USED WITHOUT WRITTEN PERMISSION

REVISION DESCRIPTION	<b>PICO-EZMATE 1.2 WIRE TO BOARD CONNECTORS SMART SPEC</b>								
CHANGE NO.	707036								
REVISED BY	PRAMOD	DATE	2022/05/17	DOC TYPE	DOC TYPE DESCRIPTION		DOC PART	SERIES	
REV APPR BY	MRAMAKRISHNA	DATE	2022/05/20	PS	PRODUCT SPECIFICATION WORD		000	78172	
INITIAL RELEASE				CUSTOMER		DOCUMENT NUMBER		REVISION	SHEET
INITIAL DRWN	MIKEDA01	DATE	2020/06/25	GENERAL		<b>781721000-PS</b>		<b>B1</b>	18 OF 18
INITIAL APPR	AIDA	DATE	2020/07/31						